

Mix-Mill Roller Mills

TRI ROLL

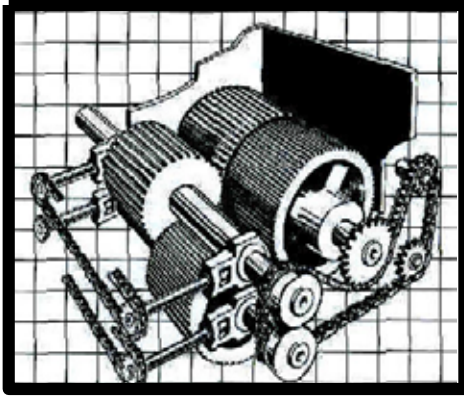

DOUBLE ROLL

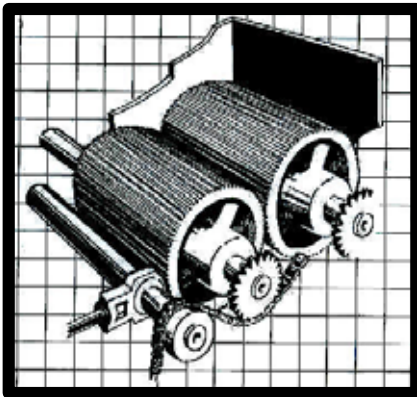

Features of the Sentry Roller Mills

- Available in either 2 roll or 3 roll for simultaneously rolling small and large grains
- Positive gear drive proportioner accurately blends up to 5 ingredients simultaneously
- Dust-tight electronic or electric control panel
- Proportioner dial settings are easily calculated
- Available in 5HP, single or 3 phase
- Roller bypass for up to 3 ingredients

Mix-Mill
CONTINUOUS WEIGHING & MIXING

1440 SOUTH ADAMS STREET, BLUFFTON, IN 46714 USA (260) 824-5213 (800) 537-6260 FAX (260) 824-5463

info@atferrell.com

www.mix-mill.com

Mix-Mill Sentry Roller Mills

Model	10 x 10	Sentry 4500	Sentry 5500
Ingredient Compartments	Tri Roll 2-4" single inlets Two Roll 4" single inlet	4-31/2" prop. comp 1-6" Prop. Comp	4-31/2 prop. comp 1-6" prop. comp.
Two-Roll 2-10x10" Rolls	Available	Available	Available
Tri-Roll 1-10x10" roll	Available	Available	Available
Grooves per Inch	5,10 or 12	5,10 or 12	5,10 or 12
Proportioner	Not Available	Yes	Yes
Control Panel	Not Available	Electric	Electronic with Optional Counters
Mill Motor	Ship (1 or 3 Phase)	Ship (1 or 3 Phase)	Ship (1 or 3 Phase)
Dimensions Height x width x depth	25 x 22-1/2 x 35 1/2" 63 x 57 x 90 cm.	55 x 37 x 36 " 140 x 94 x 91 cm.	55 x 37 x 36 " 140 x 94 x 91 cm.
Discharge auger	3 1/2 or 6"	3 1/2 or 6"	3 1/2 or 6"

*Several factors must be considered when calculating mill capacities: the type and amount of each ingredient, the amount of

Capacities*	Oats	Barley	Mixed Grain	Corn
Tri- Roll Using 2 or 3 rolls	900 lbs./Hour 400 Kilo./Hour	3300 Lbs./Hour 1500 Kilo./Hour	2200 Lbs./Hour 1000 Kilo./Hour	6000 lbs./Hour 2700 Kilo./Hour
Two-Roll 10 x 10" Rolls 5 Grooves/inch	---	---	----	11,700 lbs./Hour 5300 Kilo./Hour
Two-Roll 10 x 10" Rolls 10 grooves/inch	3300 lbs./Hour 1500 Kilo./Hour	7700 lbs./Hour 3500 Kilo./Hour	4400 lbs./Hour 2000 Kilo./Hour	-----

material ground, the amount that is bypassed, roll size and roll grooving. Capacities may vary.

Mix Mill has smart systems to produce accurate rations!

Mix Mill offers 4 different roller mill models, the top of the line Sentry 5500 lets you accurately proportion, roll and blend up to 5 different ingredients simultaneously, at the touch of a button. The Sentry 4500 has many of the features found on the Sentry 5500 but uses electro-mechanical controls instead of electronics. The 10 x 10 is simply a two or three roll mill available with or without a base and is sold without a proportioner or a control panel.



1440 SOUTH ADAMS STREET, BLUFFTON, IN 46714 USA (260) 824-5213 (800) 537-6260 FAX (260) 824-5463

info@atferrell.com

www.mix-mill.com