

Mix-Mill Nutrient Blenders



500 lb. Double Nutrient Blender

What is a Nutrient Blender?

A Nutrient Blender is a drum mixer that blends up to 500 pounds of premix, concentrate, medicated or specialty feeds on the farm, quickly and accurately.

Why should I blend my own rations?

Many rations, concentrates and premixes available to a producer do an adequate job of providing a balanced diet. Some livestock and poultry producers need more than just balanced rations.

They need to control the quality by knowing exactly what nutrients are in the ration so they can modify the formulation to follow the various stages of growth and changing health conditions of their livestock and poultry. They also need to feed these rations at the lowest cost possible.

The Nutrient Blender will help prepare fresh, consistent,

nutritionally complete feed economically and efficiently.

Saves you money

If you buy complete feed, you get grain plus a concentrate or complete supplement. Complete supplement consists of a primary protein source such as soybean meal and a relatively expensive premix or base mix of minerals, salt, vitamins, antibiotics and other additives.

Control the quality of your feed

Balanced rations formulated by an expert can be prepared on your farm to keep your herd or flock healthy and boost their production.

The Nutrient Blender lets you add exact quantities of vitamins, minerals, salt, antibiotics and other medications to a premix or a base mix and a carrier of your choice.

Mixes thoroughly and completely

The Nutrient Blender mixes ingredients inside a horizontal drum

that turns at 8 ½ rpm. Inside the drum, special mixing baffles are designed to move all the material at the same time. When the mixing cycle is complete, each micro-

ingredient will be evenly blended, no matter where you dropped it in the drum or how little of it you added.

Easy to install in any system

The Nutrient Blender can be easily adapted to your present or future feed processing system.

It is designed to discharge through a vertical auger directly into a control hopper on your hammer mill or roller mill. By connecting the Nutrient Blender's control panel to the relay on your mill's control hopper, the blender discharges automatically to keep the control hopper filled while your mill is making feed.

Mix-Mill
CONTINUOUS WEIGHING & MIXING

1440 South Adams Street, Bluffton, IN 46714 USA 260.824.3400 800.248.8318 FAX 260.824.5463

www.atferrell.com

info@atferrell.com

Easy to use

The Nutrient Blender's design is so simple, it lets you load and unload the mixing drum through the same door!

Open the loading door on the mixing drum and load your ingredients, set the timer on the machine-mounted control panel for the proper mixing time and turn on the mixing cycle. When the mixing cycle is complete, the drum will stop rotating with the loading door on top. Simply open the slide-gates on the loading door and turn on the unloading cycle. As it rotates, the drum gradually unloads itself through the slide-gates into the bottom of the Nutrient Blender. You can adjust the opening of the slide-gates for faster or slower unloading.

The cross auger and vertical auger discharge the finished concentrate or premix directly into a control hopper on your mill. The mill then proportions the concentrate or premix with other ingredients to produce a nutritionally complete ration.

Double Nutrient Blender saves you twice as much time!

Our 500-lb. model has two regular 250-lb. drums connected together. They rotate at the same time but one can be mixing while the other is unloading. You can unload a premix into your mill to make one ration while you are blending the premix for the next ration.

Cleaning is important..... so we made it easy

Medication from one batch of premix should not be left behind to contaminate the next batch. The cross auger and the vertical auger supplied with the Nutrient Blender have oversized flighting which spins very close to the inside walls of the auger tubes. These special augers leave very little residue behind. Between batches, all you have to do is to open the cleanout door of the auger corner box and run the augers.

The Nutrient Blender is Safe

All moving parts are enclosed. The drive system is completely covered by a guard hinged to the side of the machine and locked with a thumbscrew. If the large safety lid on top of the Nutrient Blender is raised during the mixing or unloading cycle, power to the drum and cross auger motor is cut instantly.

Specifications

- Control Panel
- 250 lbs Mixing Drum capacity
- Double Nutrient Blender uses two Mixing Drums
- Hinged Safety Lid safety lid
- 1/3 hp motor drives the drum and cross auger with the Nutrient Blender
- 3/4 hp motor drives
- Cross Auger w/ oversized Flighting
- Auger Corner Cleanout
- Vertical Auger Drive Kit

250 lb. Nutrient Blender

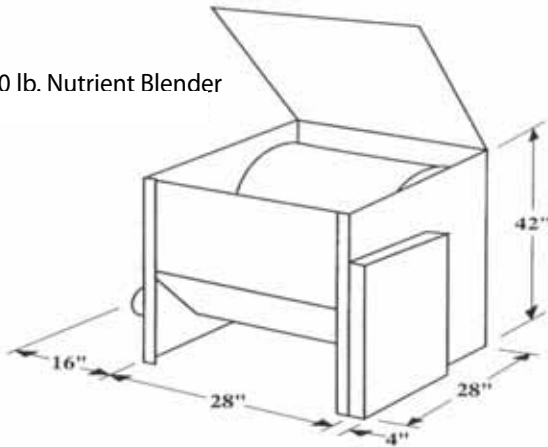

500 lb. Double Nutrient Blender

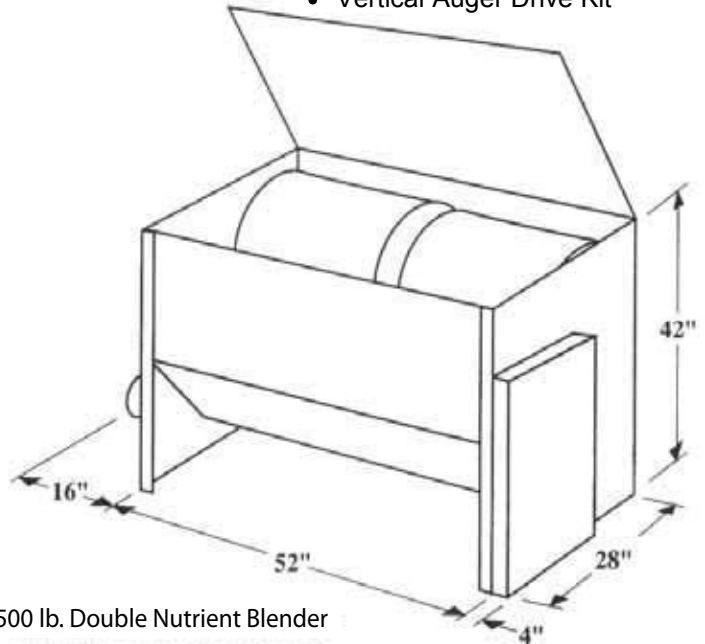

Mix-Mill
CONTINUOUS WEIGHING & MIXING